



# service bulletin

No. 94-13

## Power Trim Partial Leak Down at Maximum Trim – 75 thru 125

### Mariner and Mercury

Single Ram Power Trim

Power Trim Date Code 14182 and below.

### 1992 – 1995 75 thru 115

US

S/N 0D082000 thru 0G152528 (estimated).

Belgium

S/N 09793577 thru 09841181 (estimated).

### 1994 and 1995 125

US

S/N 0D283222 thru 0G152528

Belgium

S/N 09793577 thru 09841181

Single ram power trim units are designed to trim the outboard to a maximum of 20 degrees. Some units, when trimmed to the maximum 20 degree limit, will leak down approximately 5 degrees and then hold. The leak down will ONLY occur while the boat is under power. The cause for the 5 degree leak down is the lack of a fluid passage between the shock piston and the memory piston. For other leak down symptoms, refer to service bulletin 93-22A.

### Date Code on Power Trim

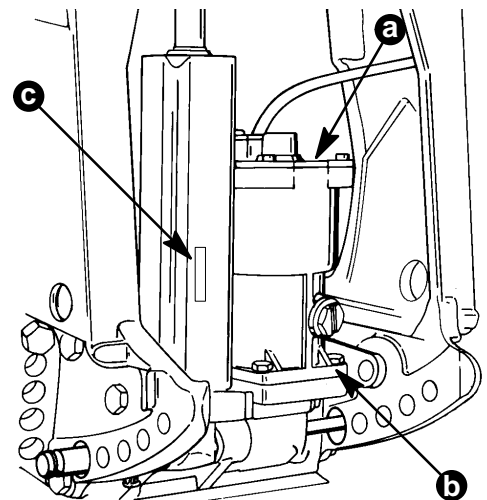
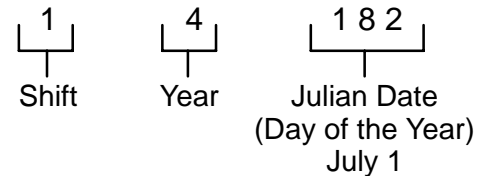

51485

- a - Label on top cover of motor.
- b - Motor reservoir flange.
- c - Embossed into the caution decal on trim/tilt cylinder (this might be difficult to read).

**Figure 1. Date Code Locations:**

## CORRECTION:

Disassemble the power trim/tilt ram assembly (refer to the service manual) and remove the memory piston. Cut a small groove .020 – .040 inch (.5 – 1 mm) deep across the top face the memory piston (figure 2). The groove will allow oil passage when the shock piston and memory piston are in contact. The groove can be easily created with a hacksaw or triangular file. Remove all burrs and filings from the memory piston. Reassemble the trim/tilt ram assembly using new O-rings and seals.

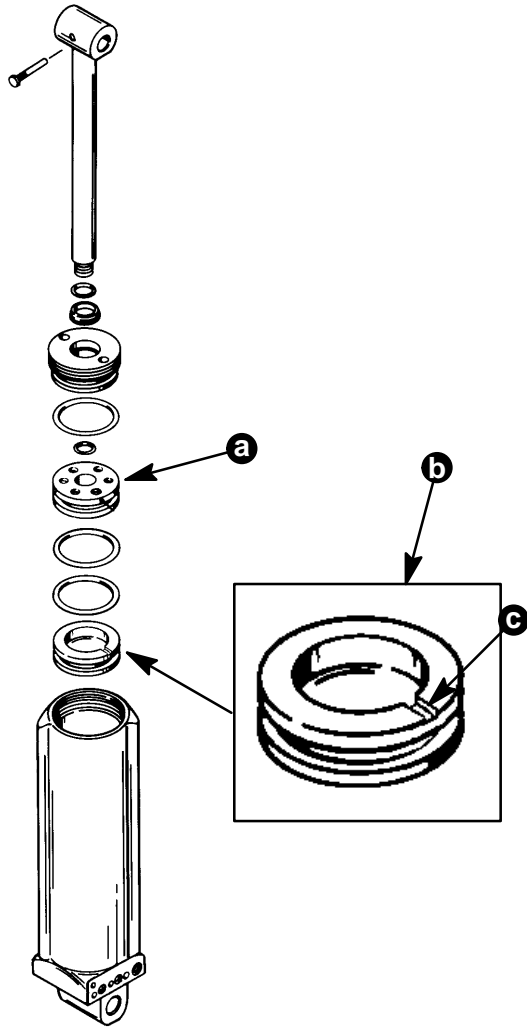

a - Shock Piston.

b - Memory Piston.

c - .020 – .040 Inch (.5 – 1 mm) Groove.

**Figure 2. Trim/Tilt Cylinder Assembly.**

## FACTORY CORRECTION:

The shock piston has a groove to allow fluid passage beginning with power trim date code 14183 and estimated serial number 0G152529. The memory piston remains the same and does not have a groove across the face.

## WARRANTY:

Complete a warranty claim listing:

Outboard serial number.

S/N 0D252460 and below

Qty. 1 P/N 811668A-1 Cylinder Rebuild Kit.

S/N 0D252461 and above

Qty. 1 P/N 813432A-3 Cylinder Seal Kit.

One and one half (1.5) hour labor.

Warranty Labor Rate Code 0H42.

Failure Code 105 26.